

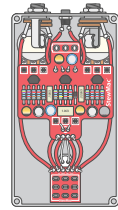

 StewMac®

**FAN TREMOLO
PEDAL KIT
INSTRUCTION GUIDE**



FROM VINTAGE WARBLE TO CHOPPY HELICOPTER SOUNDS,

this one tremolo can do it all. With three adjustable speed ranges, this pedal runs the gamut from slow, swamp-like pulses to speedy, envelope-like weirdness.

POWER

This pedal requires a standard 9V DC center-negative power supply (not included) and consumes less than 100mA. There's no battery option.

TECHNICAL SUPPORT

If you have any questions at all, our Tech Support Team is here to help. Email us at service@stewmac.com, and we'll respond quickly!

TOOLS AND SUPPLIES (REQUIRED)

Fine-gauge Wire Stripper #1606



Wire Cutter #1607



Long-nose pliers #1610



Guitar Tech Screwdriver and Wrench Set #3693



Soldering Iron #0502
Solder Wick #0504
Solder #0505



TOOLS AND SUPPLIES (HELPFUL)

PC Board Holder #0500

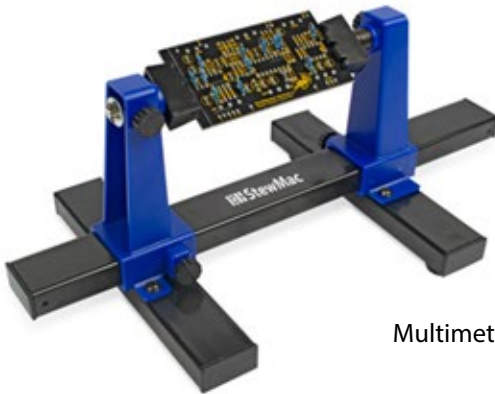

Multimeter #3607



Soldering Aids #0521



3M Gold Fre-Cut Sandpaper (220-grit) #5097



Magnifying glass or OptiVISOR #1685



Not pictured:
Clear silicone adhesive and spray finish



Resistor values are indicated by color bands, read from left to right. The first color in the code is usually the one painted closer to a lead wire. See more about resistor color codes on page 5.

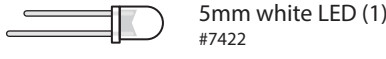
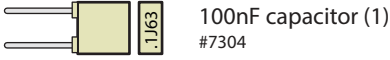
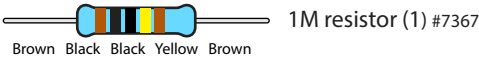
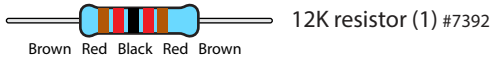
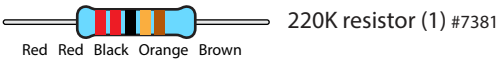
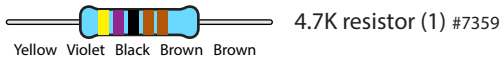
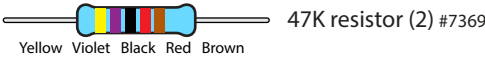
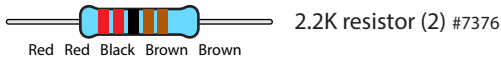
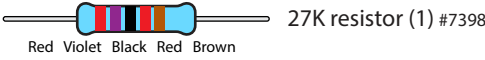
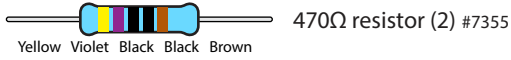
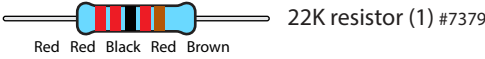
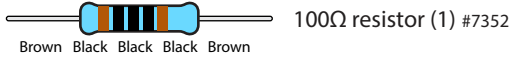

PARTS LIST (CONT)

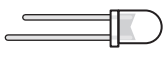
 5mm white LED (1)
#7422

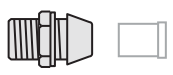
 5mm LED mounting bezel (1)
#7432

 PF5102 transistor (1)
#7518

 2N5089 transistor (1)
#7514

 2N6027 transistor (1)
#7515

 Control knob (3)
#7501

 24" of lead wire (1)
#5960

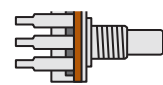
 B10K linear taper depth pot (1)
#7532

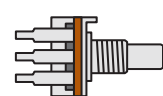
 B100K linear taper rate pot (1)
#7532

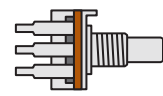
 B100K linear taper level pot (1)
#7532

 Adhesive foam tape square (4)
#7560

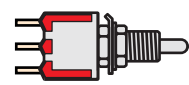
 3-way toggle switch (1)
#7465

 3PDT latching footswitch (1)
#1611

 2.1mm DC power jack (1)
#7468

 1/4" mono jack (2)
#4652

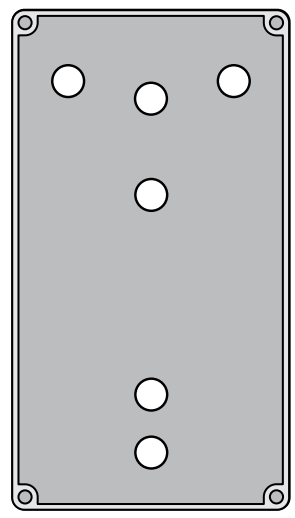

Pre-drilled enclosure top (1)
Pre-drilled enclosure bottom - not pictured (1)
Screws - not pictured (4)

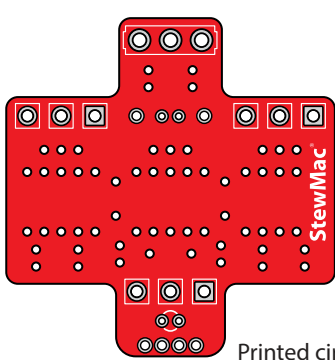

Printed circuit board (1)

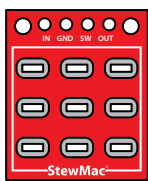

Breakout board (1)

Sticker sheet (1)

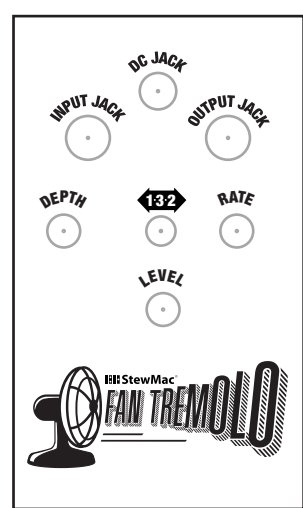

SOLDERING

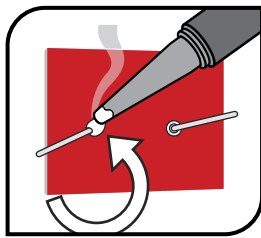
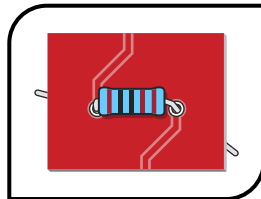
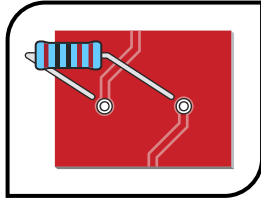

The solder joints you'll make on the printed circuit board are very small, and too much heat can damage the board. The idea is to make joints quickly, without scorching the eyelets.

1. Hold components in place for soldering by threading the leads through the board and bending them apart on the reverse side. You will be making your solder joints on the reverse side of the board.
2. Melt a small amount of solder onto the tip of the iron ("tinning" the iron).
3. Insert the tip into the eyelet and let it heat for 4-5 seconds before touching it with solder. This heats the contact enough for the solder to flow nicely without damage. Feed the solder to the eyelet, not the iron, and you don't need much solder, just enough to fill the eyelet. Keep the iron on the connection for a second longer; this pause gives time for all of the flux to cook out of the joint. After the joint has cooled, trim away the excess lead wire.

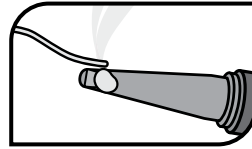

MORE HELPFUL SOLDERING TIPS AND TRICKS

- Keep your soldering tip clean by wiping it often on a damp sponge.
- Also keep it tinned by occasionally melting a little solder onto it.
- Don't blow on the hot solder or touch anything until the joint has cooled completely. A good solder joint is shiny—a sign that it was left to cool undisturbed.
- Plan so each joint is only soldered once. Resoldered joints are messy and more likely to fail.

UNDERSTANDING ELECTRONIC COMPONENTS

A number of different components are used to make an effects pedal. Here is a look at the components used in this kit:

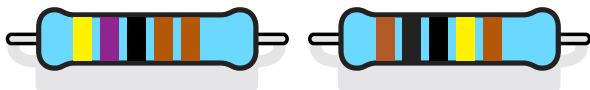

RESISTORS

A resistor does exactly what it says—it resists the flow of current. The designated value of the resistor corresponds to how much resistance there is on the flow of electrons.

A resistor's value—the amount of resistance it creates—is rated in ohms (Ω). Larger ohm values mean more resistance. For example, a 100Ω resistor creates ten times as much resistance as a 10Ω resistor.

Resistor values are indicated by color bands, read from left to right. The first color in the code is usually

	Band 1 1st Digit	Band 2 2nd Digit	Band 3 3rd Digit	Band 4 Multiplier	Band 5 Tolerance
BLACK	0	0	0	1	
BROWN	1	1	1	10	+/- 1%
RED	2	2	2	100	+/- 2%
ORANGE	3	3	3	1,000	
YELLOW	4	4	4	10,000	
GREEN	5	5	5	100,000	+/- .5%
BLUE	6	6	6	1,000,000	+/- .25%
VIOLET	7	7	7	10M	+/- .1%
GRAY	8	8	8	.01	SILVER
WHITE	9	9	9	.1	GOLD

6 8 0 x100 +/- 1%
Blue Gray Black Red Brown
68K +/- 1%
K=1,000



the one painted closest to a lead wire. When a gold or silver band is present, it's always one of the last colors in the code. If you're having trouble reading the color bands, try using a multimeter to read the resistor's value. Just set your multimeter to ohms and connect its test leads to each side of the resistor.

UNDERSTANDING ELECTRONIC COMPONENTS

CAPACITORS

The two main uses of capacitors are to store electricity and to block the flow of DC current.

Capacitor values are typically printed on the component. The key values with caps are their voltage and capacitance.

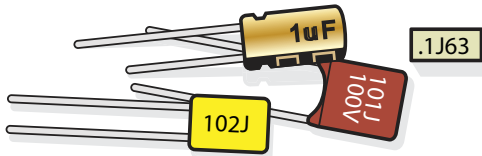

The voltage spec for a cap refers to how much DC voltage it can handle at any given time. If this rating is exceeded, the capacitor will fail.

Capacitance, measured in farads, refers to how much electricity a capacitor can hold. One farad (1F) would be much too large for use in a pedal. Caps for pedals are rated between millionths of a farad, called microfarads (μF), billionths of a farad,

called nanofarads (nF), or trillionths of a farad, called picofarads (pF). $.001\mu\text{F} = 1\text{nF} = 1,000\text{pF}$.

Resistors and capacitors may also be referred to with shorthand notation on the printed circuit board when there is a decimal in the value. For example, the place on the printed circuit board for the 4.7K resistor will read 4K7 and the spot for a 2.2nF capacitor will read 2n2. This is done to save space on the board and make the labels as clear as possible.

Some capacitors have polarity and some don't. It's extremely important to install polarized caps correctly in a circuit. The negative lead will often be indicated by a stripe on the negative lead's side (often with arrows) and will be shorter than the positive lead. The positive lead of an electrolytic cap will be longer and won't have the stripe on that side.



Installing capacitors with the polarity backwards will make the circuit malfunction and quickly destroy the capacitor—even causing it to explode.

DIODES

Diodes are used where you want electricity to flow in only one direction, such as power rectification, and also to limit how much current can flow, to create "clipping" distortion.

Diodes are also polarized, so they need to be installed in the correct orientation. The stripe around one end marks the negative (-) lead of the diode. On the printed circuit board, the printed outline of the diodes also shows this stripe. Install each diode so that its stripe matches the direction shown on the printed circuit board.

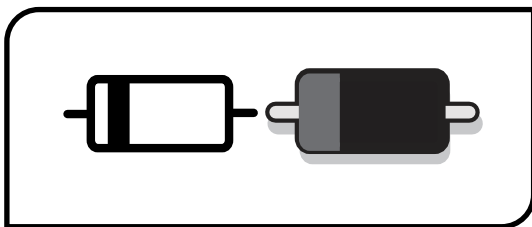

TRANSISTORS

Transistors are used to amplify electrical signals. They have a flat side and a round side. The location on the printed circuit board also has a flat side and a round side. Match the orientation of the component to this outline.

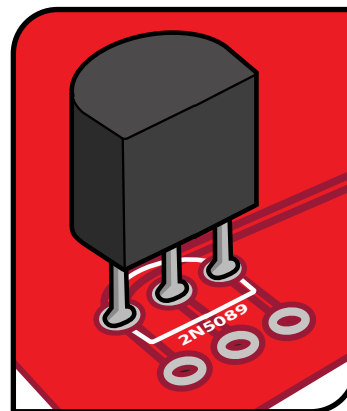

UNDERSTANDING ELECTRONIC COMPONENTS

POTENTIOMETERS

A potentiometer, or pot, is a variable resistor. This means as the knob shaft is rotated, the DC resistance will change. There are three lugs or soldering terminals on a conventional potentiometer. The outside two are the ends of the resistive strip, and the center lug is connected to the wiper. The wiper allows you to vary the DC resistance relative to its position along the resistive



strip, or relative to the outer two lugs.

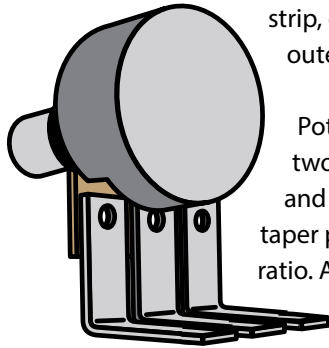

Potentiometers come in two varieties, linear taper and audio taper. The linear taper pot's taper works at a 1:1 ratio. Audio taper has a special logarithmic ratio.

Audio taper is used because our ears don't hear changes in volume in a linear fashion as you might expect. As the volume increases, a greater change in signal or sound pressure is required to perceive a smooth transition.

LEDs

LED stands for Light Emitting Diode, and functionally LEDs are very similar to regular diodes. LEDs are most often used as indicator lights in pedals. They are polarized just like diodes and electrolytic capacitors and must be installed in the correct orientation to work. The positive (anode) lead of the LED will be longer and the anode side of the LED housing will be round. The negative (cathode) lead of the LED will be shorter and the cathode side of the LED housing will be flat. LEDs are mounted inside of a bezel, which protects the LED and insulates the leads from shorting against the enclosure or any internal components.

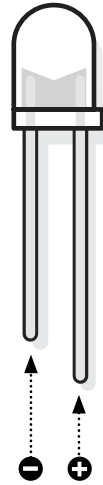

1
PAINTING YOUR PEDAL ENCLOSURE

You're creating a pedal from the ground up, so add your own custom paint job too! Painting your pedal and adding the stickers provided in this kit (or custom decals that you can create on your own) in advance is not only fun, but it's much easier than disassembling the pedal to paint it once you have put it together.

1. To minimize redoing steps, make sure you have a solid idea of the look and feel you're going for.

2. Lightly sand the outside of the enclosure with 220-grit sandpaper and wipe clean any debris.

3. Cover the holes from the inside with masking tape.

4. On a piece of cardboard, place the enclosure and bottom cover on scraps of wood to lift them off the cardboard when spraying.

5. With long, even strokes, spray a light coat of primer or paint. Allow 45 minutes of drying time before the next coat.

6. If you're using primer-followed-by-paint method, paint three coats with 45 minutes between coats.

7. Now, add your included stickers and any other desired decoration (paint pens, acrylic paint, Sharpie, etc.). Allow drying time.

8. Add three coats of clear-coat glaze with 45 minutes between coats. Wait at least two hours before adding parts.





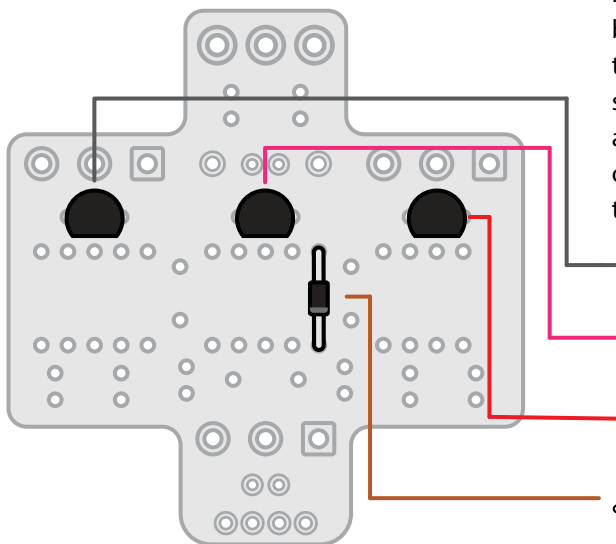
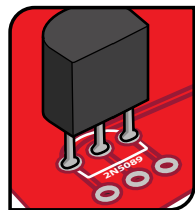

2
INSTALL THE DIODE AND 3 TRANSISTORS

It's time to install your parts! Before soldering the diodes and transistors to your printed circuit board, make sure you thread the leads through the correct side. The side of the printed circuit board that has white values and outlines of the components is the correct side. In some cases, components must be inserted into the printed circuit board in a specific direction due to their polarity, so follow the graphics carefully.



Note the stripe around one end of the diode. This marks the negative (-) lead. On the printed circuit board, the printed outline of the diode also shows this stripe. Install each diode to match the direction shown, and solder in place. Similarly, the transistors are directional, and must be installed in a specific orientation. Match the flat side of the transistors to the outline printed on the printed circuit board.

-  2N6027 transistor (1)
#7515
-  2N5089 transistor (1)
#7514
-  PF5102 transistor (1)
#7518
-  1N5817 rectifier diode (1)
#7522

3
INSTALL 13 RESISTORS

Next, we're going to add a bunch of resistors to our printed circuit board. As in the previous step, you'll find an outline of each resistor and its value printed in their proper location on the printed circuit board. Match resistors to the values on the printed circuit board and solder in place.

Resistors are not polarized, so it doesn't matter which lead goes in which eyelet.

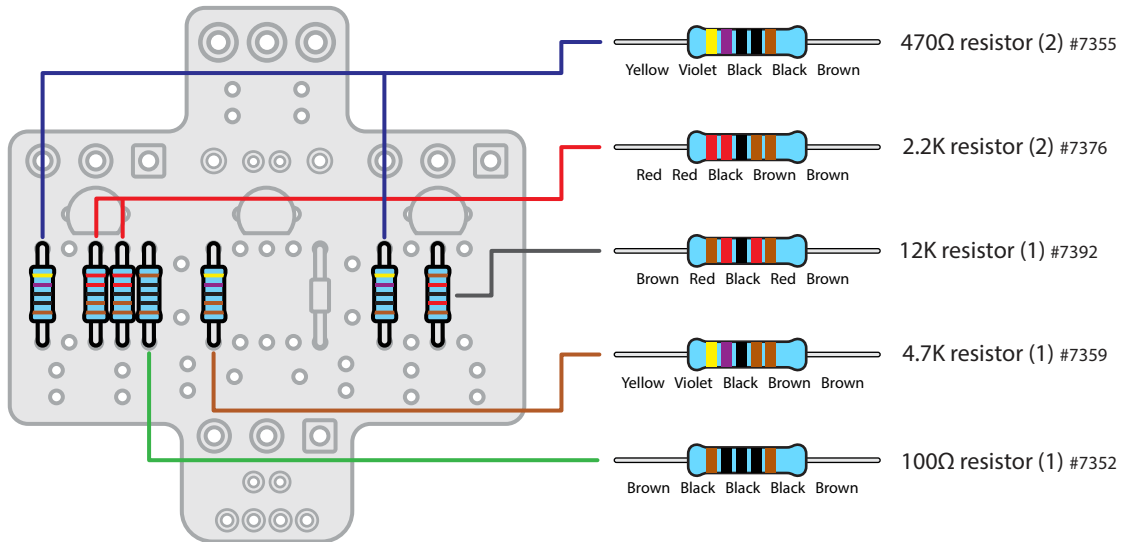

Resistors have a low profile, sitting closer to the board than taller components, so installing these now will make installing other parts easier later on.

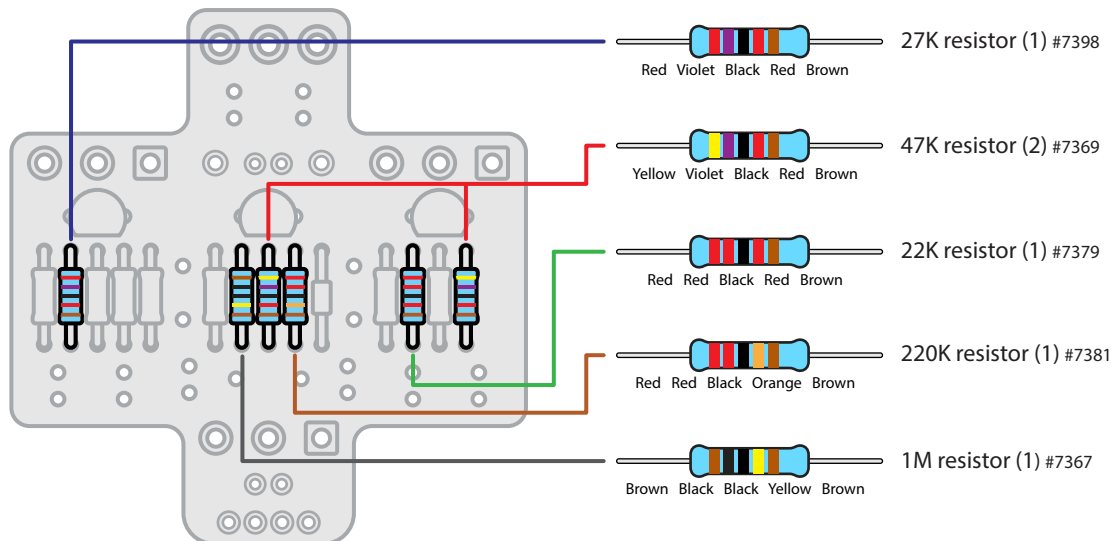
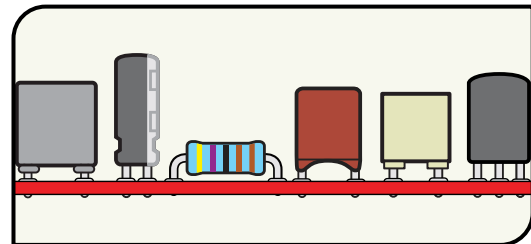

4
INSTALL 8 CAPACITORS

The three types of capacitors shown below are polarized and must be installed in the correct orientation. Note the stripe running the length of each cap; this identifies the negative (-) lead (the negative lead is also shorter).

On the printed circuit board, each capacitor has a square-shaped eyelet marked positive (+). The negative lead's eyelet is round.

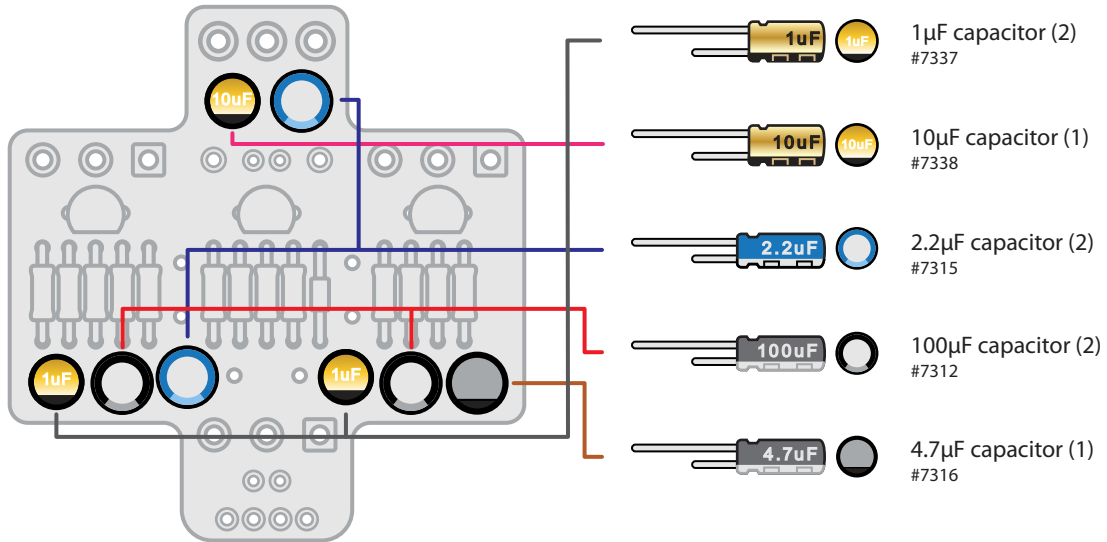

5
INSTALL 3 CAPACITORS

The remaining capacitors below are not polarized. However, best practice is to solder these caps in place all facing the same direction when possible.

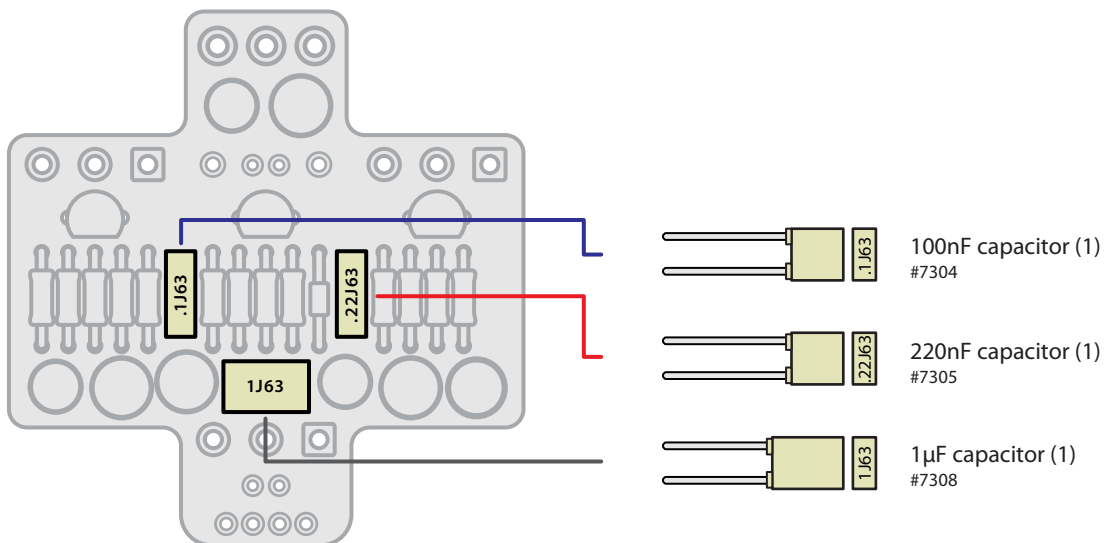

6
INSTALL THE SWITCH

One 3-way toggle switch is included with the kit. Slide the switch lugs through the back of the three eyelets at the top of the printed circuit board and solder them.

You can use the pedal enclosure as a mount for the toggle switch while you solder it to the printed circuit board. Just lay the enclosure face-up and drop the switch in its hole. You don't even need to fasten it with a nut while you solder.

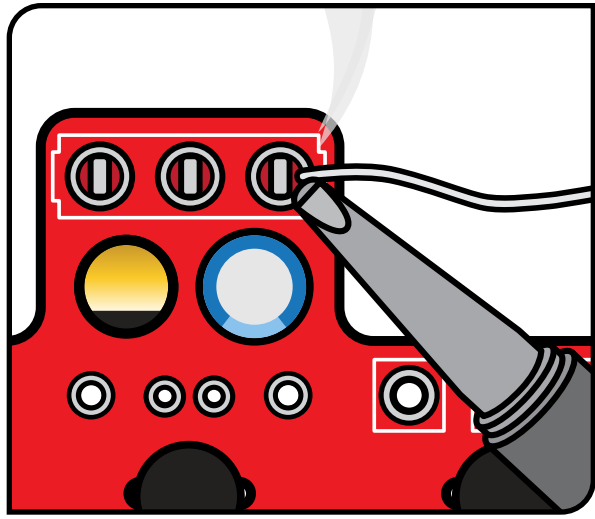
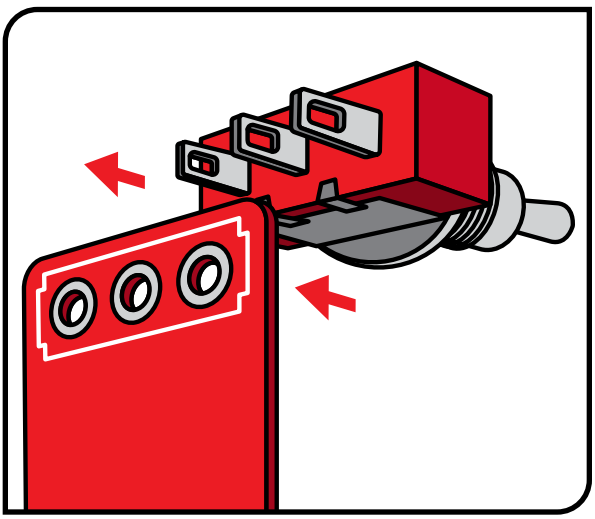

7
INSTALL 8 LEAD WIRES

- The kit comes with 24" of lead wire.
- Cut the wire into eight 2" sections and two 4" pieces.
- Strip around 3/32" off both ends of all wires.
- Solder the eight 2" leads onto the printed circuit board in the locations shown in the diagram.

TIP We find it easiest to feed each lead through the bottom of the printed circuit board and solder it on the top of the board.

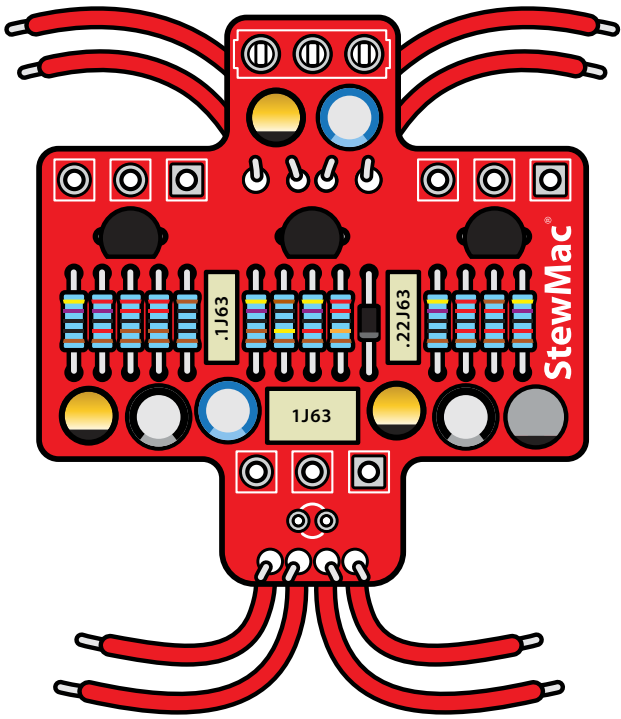

8
INSTALL FOOTSWITCH INTO BREAKOUT BOARD

Orient the breakout board with the text facing up, reading left to right. Slide the lugs of the footswitch up through the bottom of the board.

If the lugs of the footswitch don't quite fit in the breakout board, use a pair of pliers to gently bend the lugs of the footswitch until the breakout board slides over the lugs. Solder each lug to the corresponding breakout board eyelet.

TIP
 You can use the pedal enclosure as a mount for the footswitch while you solder the breakout board to it. Just lay the enclosure face-up and drop the switch in its hole. No need to fasten it with a nut from the back if you don't want to.

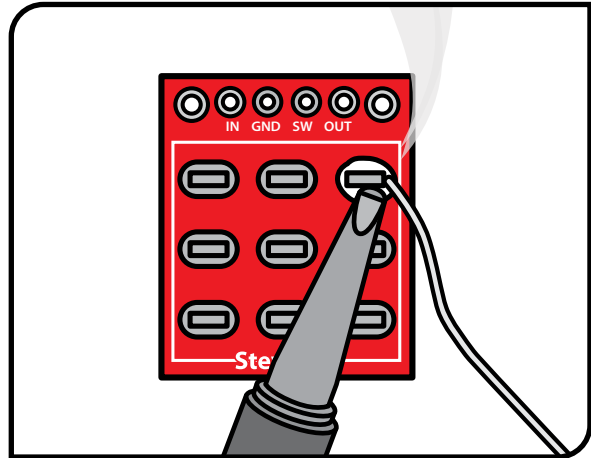
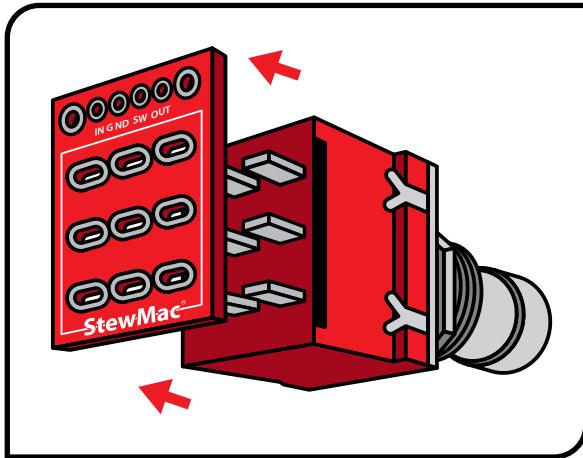

9
ATTACH 6 WIRES TO BREAKOUT BOARD

Solder the four wires from the bottom of the printed circuit board to eyelets in the breakout board as shown.

Solder one end of each 4" wire to the last two eyelets on the breakout board.

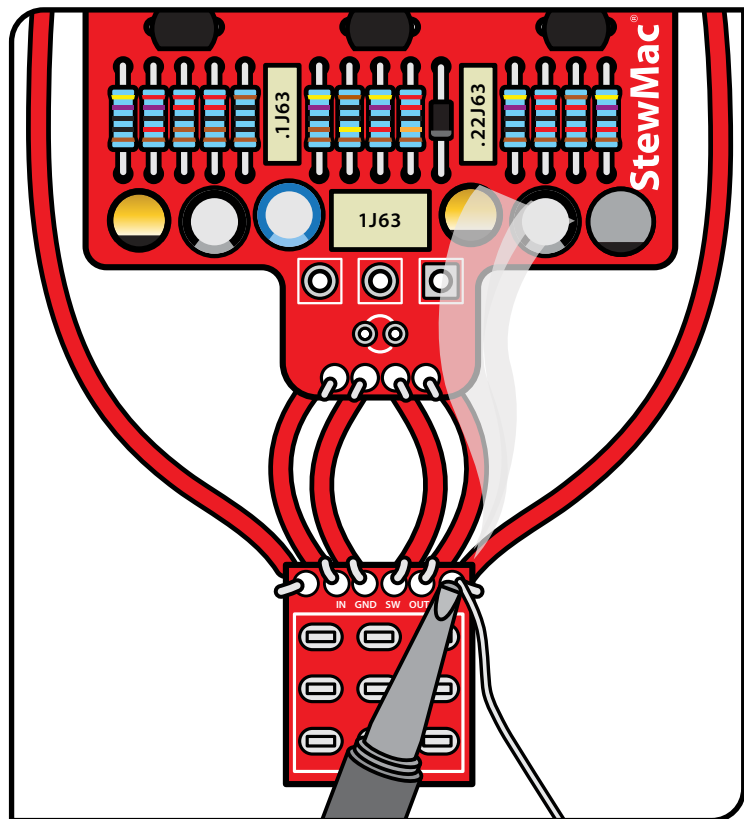

10

INSTALL 3 POTS AND ATTACH FOAM TAPE

The last components to go onto the printed circuit board are the three control pots. They install on the back of the board. Each pot has three connecting lugs. Note the orientation of each pot.

If any pot has an index pin protruding from the case, break it off before installation, so the pot will mount flush against the pedal case. Long-nose pliers work well for removing pins.

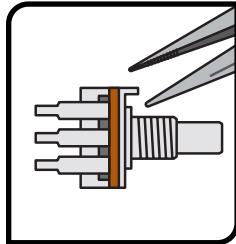

Use a piece of the adhesive foam tape to insulate the back of the pots from the soldered leads of the other parts on the printed circuit board.

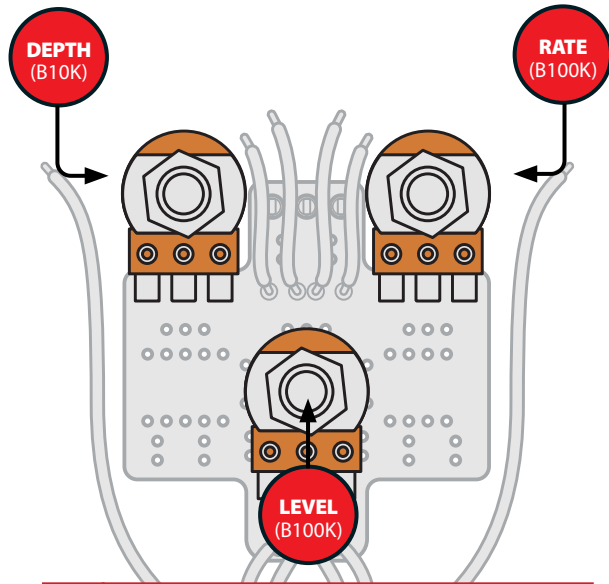
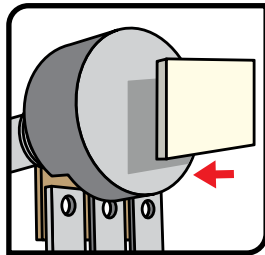

TIP

Once you've removed any index pins and added the foam tape to the back of each pot, use the pedal enclosure as a mount for the control pots while you solder the printed circuit board to them. Just lay the enclosure face-up and arrange the pots in their holes. No need to fasten them with a nut from the back if you don't want to.

11

SOLDER POTS TO PRINTED CIRCUIT BOARD

Solder the pots in place, making sure the foam back stays on the back of the pot. This insulates the solder joints on the printed circuit board from shorting to the housing of the pot.

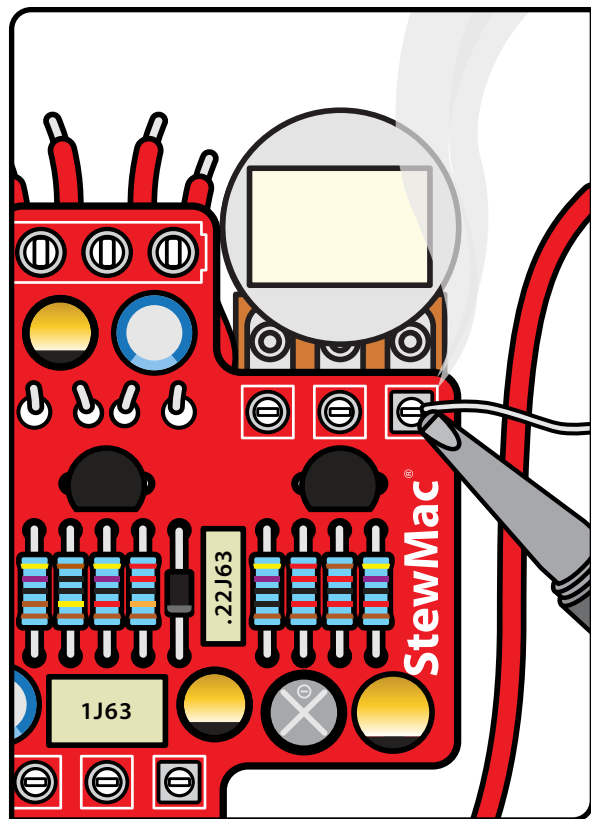
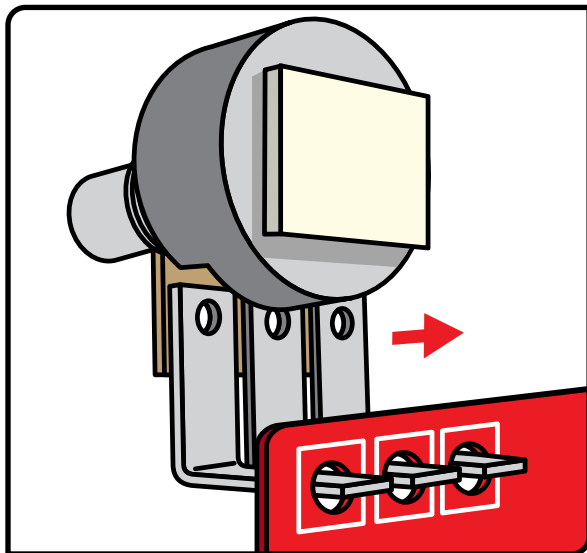

12

INSTALL LED AND TOGGLE SWITCH

Like some of the caps and diodes, the LED is polarized and has to be installed in a specific direction. The negative lead of the diode has a flat edge and is shorter than the positive.



The LED mounting bezel consists of two main parts: A ring that the LED fits into, and a plastic plug that goes over the LED from the back side to keep it in place.

Install the LED mounting bezel using its lock washer and 3/8" nut. Insert the LED into the bezel with the flat side (shorter lead) facing right when seen from inside as shown. Feed the leads through the plastic plug, and press the plug into the bezel. The LED will be held in place when you solder the leads in the next step. For a more secure mount, run a bead of clear silicone adhesive around the plug.

Install the toggle switch using its lock washer and 3/8" nut.

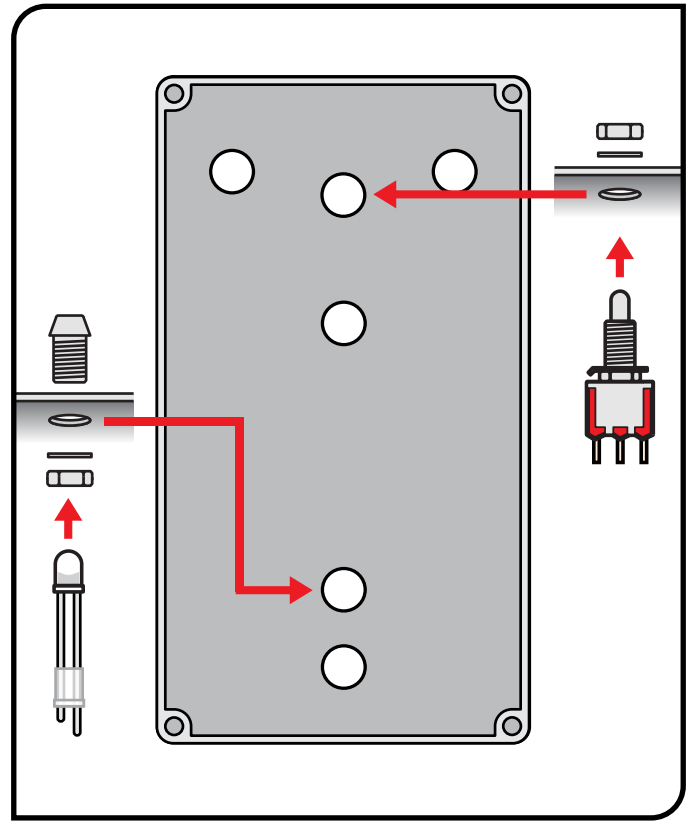

13

INSTALL PRINTED CIRCUIT BOARD

The printed circuit board is held in place by the control pots, but the LED leads need to pass through their eyelets in the printed circuit board before the pots will pass through the enclosure.

Pass the longer positive lead of the LED through the eyelet marked "A" and the shorter negative lead through the eyelet marked "K". Next, secure the pots by installing their shafts through the enclosure and slide washers onto them on the outside. Using a 10mm wrench, install the mounting nuts so they are good and snug, but take care not to overtighten. Once the pots are secured to the enclosure, solder the leads of the LED in place.

Install the footswitch through the top of the case and slide a washer onto it from the outside. Use a 14mm wrench to tighten it up. The footswitch is the effect bypass switch that turns the pedal on.

Do not connect any of the lead wires at this point. Once all of the pots are tightened down, twist the pot shafts all the way counter-clockwise and install the knobs pointing at "7 o'clock" indicating the "zero" position.

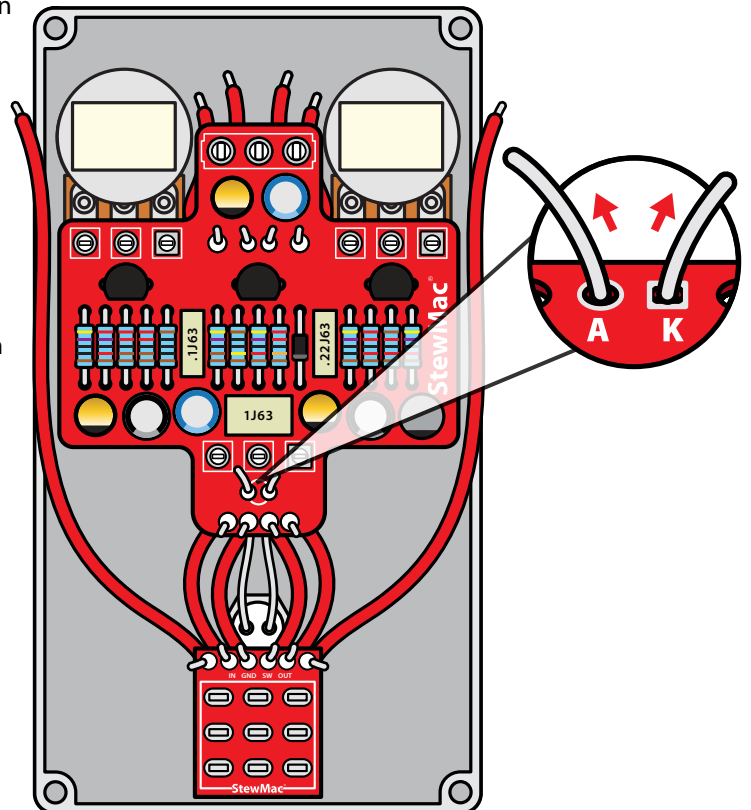

14
INSTALL THE DC POWER JACK

Insert the DC power jack into the center hole in the top of the enclosure making sure the longer of the two lugs is on the left. Use a 14mm wrench on the included nut to secure the jack into the enclosure.

Solder the inside left wire to the longer lug of the DC jack.

Solder the inside right wire to the shorter lug of the DC jack.

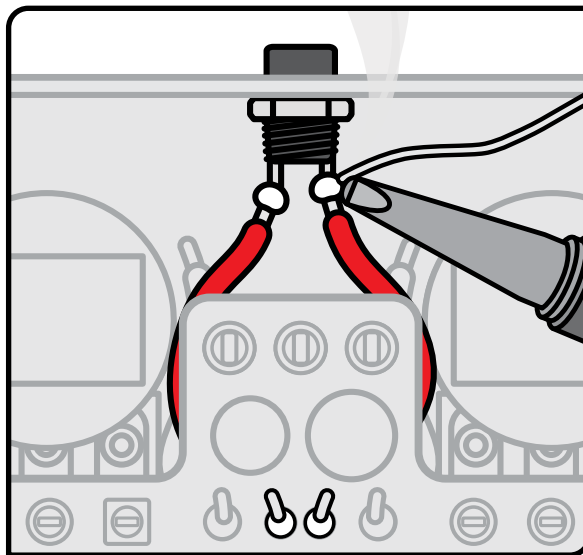
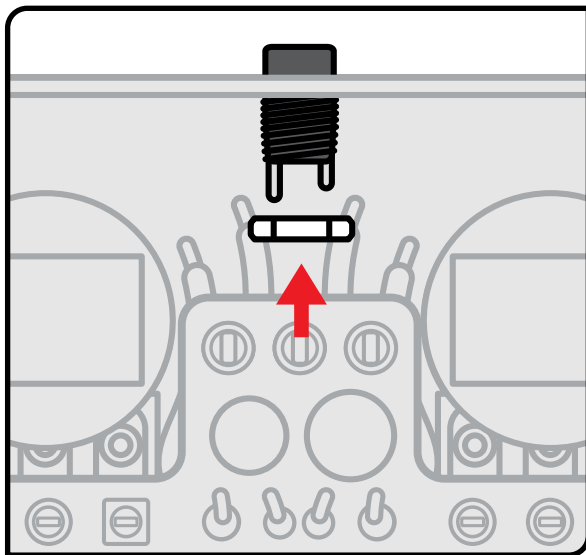

15
INSTALL THE INPUT JACK

Insert the input jack into the left side hole in the top of the enclosure with the tip connection facing down, as shown in the diagram. Add the washer, and thread the nut onto the shaft enough so that the jack can rotate freely. You may need to rotate the jack to provide easier access to setting the solder joints.

Solder the left-most wire at the top of the printed circuit board to the input jack lug that corresponds with the sleeve connection. The sleeve lug should be the one closer to the DC jack.

Solder the 4" wire on the left side of the breakout board to the lug of the input jack that corresponds with the tip connection. The tip lug should be the one closer to the outside wall of the enclosure.

Once the solder has cooled, orient the jack as shown in the diagram, making sure none of the connections on the jack are touching any other components, and tighten the nut on the jack.

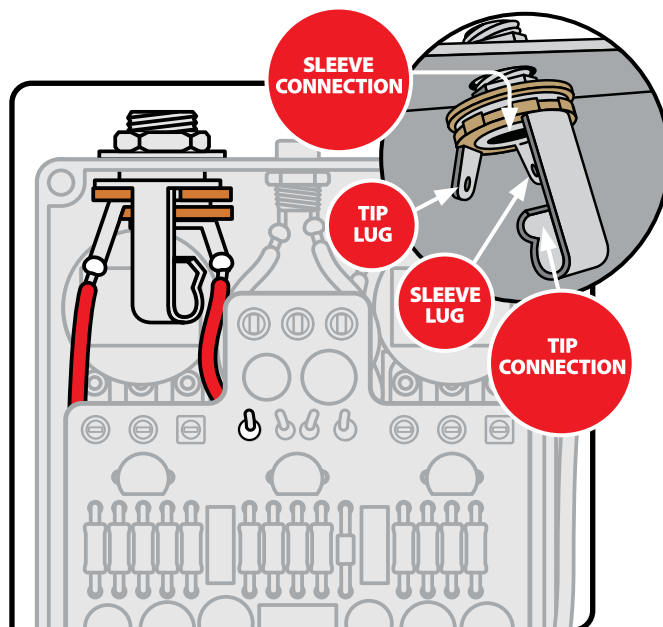

16
**INSTALL
THE OUTPUT
JACK**

Insert the output jack into the right side hole in the top of the enclosure with the tip connection facing up, as shown in the diagram. Add the washer, and thread the nut onto the shaft enough so that the jack can rotate freely. You may need to rotate the jack to provide easier access to setting the solder joints.

Solder the right-most wire at the top of the board to the output jack lug that corresponds with the sleeve connection. The sleeve lug should be the one closer to the DC jack.

Solder the 4" wire on the right side of the breakout board to the lug of the output jack that corresponds with the tip connection. The tip lug should be the one closer to the outside wall of the enclosure.

Once the solder has cooled, orient the jack as shown in the diagram, making sure none of the connections on the jack are touching any other components, and tighten the nut on the jack.

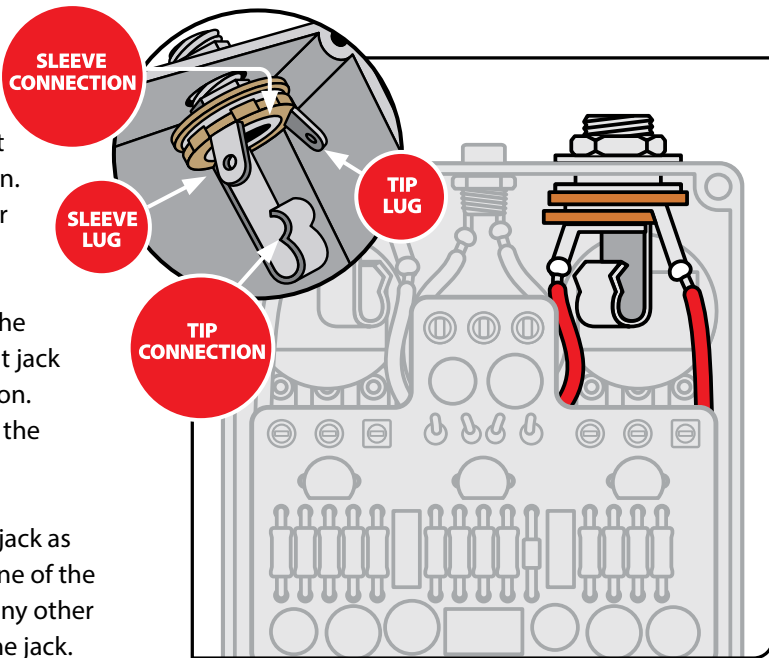

17
**COMPLETED
VIEW**

With the output jack secured, this is what your pedal should look like.

Congrats on a job well done.

Now, simply attach the bottom of the enclosure with the included screws, plug it in and bend some tone!

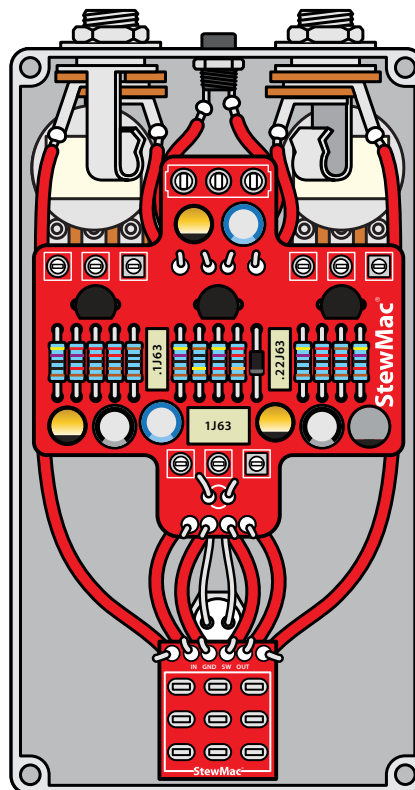

HERE'S HOW THE CONTROLS WORK

POWER: Use a standard 9 volt DC power supply with a 2.1mm negative-center barrel (not included). We always recommend pedal-specific, transformer-isolated, wall-wart power supplies or supplies with separate isolated outputs. Pedals will make extra noise if there is ripple or unclean power. Switching-type power supplies, daisy chains, and non-pedal specific power supplies do not filter dirty power as well and let through unwanted noise. Do not run at higher voltages! Current draw is 25 mA.

DEPTH: This control could also be labeled Mix or Intensity. A low setting will have a very low effect on the signal and the more you turn the knob the more intense or “deep” the tremolo effect will be.

MODE: This 3-way toggle switch selects which type of oscillation you would like. All the way left is a subtle, early '60s style oscillation. All the way right is a slightly faster and heavier “opto-isolator” style tremolo, more like the effect found in amps in the late '60s and '70s. The middle position is a very modern, almost digital-style oscillation that can easily achieve ring-mod style tremolo.

RATE: This adjusts the speed of the oscillations.

LEVEL: There is a slight boost in the circuit to help compensate for the perceived volume drop associated with tremolo effects. A lower setting means a lower output, and a higher setting results in, you guessed it, a higher output. We're guilty of sometimes turning the depth very low and the level up higher and using this pedal as a clean boost with a touch of shimmer.

